

MODEL Z07 HEAVY DUTY RIGID COUPLING -Angle-Pad Design-

The **Shurjoint** Model Z07 is an angle-pad design rigid coupling for general piping applications where rigidity is required including valve connections, mechanical rooms, fire mains and long straight runs. The angle-pad design allows the coupling housings to slide along the bolt pads when tightened. The result is an offset clamping action which provides a rigid joint that resists flexural and torsional loads. Support and hanging requirements correspond to ANSI B31.1, B31.9 and NFPA 13.

The **Shurjoint** Model Z07 is available with a standard "C" shaped or **GapSeal** gasket in a variety of grades to meet your specific service requirements.



Z07 couplings should always be installed so that the coupling bolt pads make metal to metal contact.

For Fire Protection pressure rating, listing, and approval information, refer to Data Sheet B-42 or visit **SHURJOINT** website, www.shurjoint.com for details or contact your **SHURJOINT** Representative.

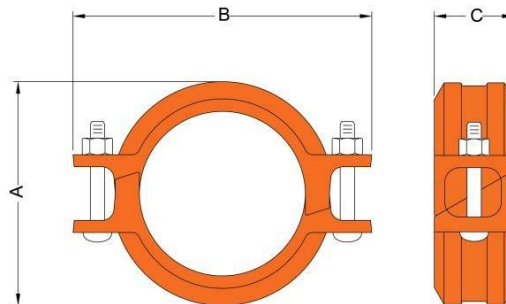

Full warranty terms can be found on www.shurjoint.com

Model Z07 Heavy Duty Rigid Coupling											
Nominal Size	Pipe O.D.	Max. Working Pressure (CWP)*	Max. End Load (CWP)	Axial Displacement †	Dimension			Bolt No	Bolt Size	Weight	
					A	B	C				
in	in	PSI	Lbs	in	in	in	in	in	Lbs		
mm	mm	Bar	kN	mm	mm	mm	mm	mm	Kgs		
1¼	1.660	750	1620	0 ~ 0.05	2.68	4.13	1.85	2	¾ x 2½	1.6	
32	42.2	52	7.27	0~1.2	68	105	47		M10 x 55	0.7	
1½	1.900	750	2120	0 ~ 0.05	2.91	4.53	1.85	2	¾ x 2½	2.0	
40	48.3	52	9.52	0~1.2	74	115	47		M10 x 55	0.9	
2	2.375	750	3320	0 ~ 0.07	3.39	4.69	1.88	2	¾ x 2¾	2.4	
50	60.3	52	14.84	0~1.7	86	119	48		M10 x 70	1.1	
2½	2.875	750	4860	0 ~ 0.07	3.94	5.50	1.88	2	¾ x 2¾	2.4	
65	73.0	52	21.75	0~1.7	100	140	48		M10 x 70	1.1	
76.1 mm	3.000	750	5290	0 ~ 0.07	4.00	5.75	1.88	2	¾ x 2¾	2.4	
	76.1	52	23.64	0~1.7	102	146	48		M10 x 70	1.1	
3	3.500	750	7210	0 ~ 0.07	4.53	6.54	1.88	2	½ x 3	3.1	
80	88.9	52	32.26	0~1.7	115	166	48		M12 x 75	1.4	
4	4.500	750	11920	0 ~ 0.16	5.78	8.11	2.13	2	½ x 3	4.4	
100	114.3	52	53.33	0~4.1	147	206	54		M12 x 75	2.0	
139.7 mm	5.500	750	17810	0 ~ 0.16	6.88	9.37	2.09	2	¾ x 3½	6.6	
	139.7	52	79.66	0~4.1	175	238	53		M16 x 90	3.0	
5	5.563	750	18220	0 ~ 0.16	6.97	9.45	2.09	2	¾ x 3½	6.6	
125	141.3	52	81.50	0~4.1	177	240	53		M16 x 90	3.0	
165.1 mm	6.500	700	23210	0 ~ 0.16	7.87	10.47	2.09	2	¾ x 3½	7.5	
	165.1	48	102.71	0~4.1	200	266	53		M16 x 90	3.4	
6	6.625	700	24110	0 ~ 0.16	8.00	10.67	2.09	2	¾ x 3½	7.1	
150	168.3	48	106.73	0~4.1	203	271	53		M16 x 90	3.2	
8	8.625	600	35030	0 ~ 0.19	10.55	13.46	2.52	2	¾ x 4¾	15.7	
200	219.1	42	158.27	0~4.8	268	342	64		M20 x 120	7.1	
10	10.750	500	45350	0 ~ 0.13	12.86	15.60	2.56	2	¾ x 6½	27.4	
250	273.0	35	204.77	0~3.2	327	396	65		---	10.4	

Model Z07 Heavy Duty Rigid Coupling

Nominal Size	Pipe O.D.	Max. Working Pressure (CWP)*	Max. End Load (CWP)	Axial Displacement †	Dimension			Bolt		Weight
					A	B	C	No	Size	
in mm	in mm	PSI Bar	Lbs kN	in mm	in mm	in mm	in mm	No	in mm	Lbs Kgs
12 300	12.750 323.9	400 28	51040 230.59	0 ~ 0.13 0~3.2	14.86 377	17.80 452	2.56 65	2	7/8 x 6 1/2 ---	26.0 11.8
200 JIS	8.516 216.3	600 42	34150 154.25	0 ~ 0.13 0~3.2	10.39 264	13.35 339	2.50 64	2	3/4 x 4 3/4 M20 x 120	16.3 7.4
250 JIS	10.528 267.4	500 35	43500 196.45	0 ~ 0.13 0~3.2	12.63 321	15.63 397	2.56 65	2	7/8 x 6 1/2 ---	23.1 10.5
300 JIS	12.539 318.5	400 28	49360 222.97	0 ~ 0.13 0~3.2	14.65 372	17.80 452	2.56 65	2	7/8 x 6 1/2 ---	27.4 12.4

* Working Pressure is based on roll grooved standard wall carbon steel pipe.

† Allowable Axial Displacement and Angular Movement (deflection) figures are for roll grooved standard steel pipe. Values for cut grooved pipe will be double that of roll grooved. These values are maximums; for design and installation purposes these figures should be reduced by: 50% for 3/4" – 3 1/2"; 25% for 4" and larger to compensate for jobsite conditions.

MATERIAL SPECIFICATIONS

• Housing:

Ductile Iron to ASTM A536, Gr. 65-45-12 and or ASTM A395 Gr. 65-45-15, min. tensile strength 65,000 psi (448 MPa).

• Surface Finish:

Standard painted finishes in orange or RAL3000 red.

- Hot dip zinc galvanized (Optional).
- Epoxy Coatings in RAL3000 red or other colors (Optional)

• Rubber Gasket:

Grade "E" EPDM (Color code: Green stripe) Good for cold & hot water up to +230°F (+110°C). Also good for services for water with acid, water with chlorine, deionized water, seawater and waste water, dilute acids, oil-free air and many chemicals.

Not recommended for petroleum oils, minerals oils, solvents and aromatic hydrocarbons.

Maximum Temperature Range: -30°F (-34°C) to +230°F (+110°C) *.

*EPDM gaskets for water services are not recommended for steam services unless couplings or components are accessible for frequent gasket replacement.

- (Option) **Grade "E-pw" EPDM** (Color code: Double Green stripe) for portable water and food processing services. The Grade "E-pw" is UL classified per NSF/ANSI 61 and NSF/ANSI 372 for cold +86° F (30° C) and hot +180° F (-82° C) portable water services.

Temperature range: -30° F (-34° C) to +230° F (+110° C)

- (Option) **Grade "T" Nitrile** (Color code: Orange stripe) Recommended for petroleum products, air with oil vapors, vegetable and mineral oils within the specified temperature range. Also good for water services under +150°F (+66°C). Temperature range: -20° F to +180° F (-29° C to +82° C).

Do not use for HOT WATER above +150 F (+66 C) or HOT DRY AIR above +140 °F (+60 °C).

- Other options: Grade "O" - Fluoroelastomer.
Grade "L" - Silicone.

For dry systems we recommend the use of the **Shurjoint** GapSeal gasket.

For additional details contact **Shurjoint**.

• Bolts & Nuts:

Heat treated carbon manganese steel track bolts to ASTM A449-83a (or A183 Gr. 2), minimum tensile strength 110,000 psi (758 MPa), Zinc electroplated, with heavy-duty hexagonal nuts to ASTM A563.

Performance Data

The following tables show the maximum working pressures (CWP) of **Shurjoint** Model Z07 Standard Rigid Coupling used on both carbon steel and stainless steel pipes. **Shurjoint** ductile iron couplings can be used in conjunction with stainless steel pipe in non-corrosive environment as the flow media does not come in direct contact with the coupling housings but rather only the gasket.

Unit: psi / Bar

Model Z07 on Carbon Steel Pipe					
Nom. Size	Cut-Grooved		Roll-Grooved		
	XS	STD	STD	Sch. 10	Sch. 7
in / mm					
1¼	750	750	750	600	400
32	52	52	52	42	28
1½	750	750	750	600	400
40	52	52	52	42	28
2	750	750	750	600	400
50	52	52	52	42	28
2½	750	750	750	600	400
65	52	52	52	42	28
3	750	750	750	600	400
80	52	52	52	42	28
4	750	750	750	600	400
100	52	52	52	42	28
5	750	750	750	500	350
125	52	52	52	35	24
6	700	700	700	400	300
150	48	48	48	28	20
8	600	600	600	350	250
200	42	42	42	24	17
10	500	500	500	300	200
250	35	35	35	20	14
12	400	400	400	250	150
300	28	28	28	17	10

Unit: psi / Bar

Model Z07 on Stainless Steel Pipe					
Nom. Size	Cut-Grooved		Roll-Grooved		
	Sch. 80S	Sch. 40S	Sch. 40S	Sch. 10S	Sch. 5S
in / mm					
1¼	750	750	700	500	300
32	52	52	48	35	20
1½	750	750	700	500	300
40	52	52	48	35	20
2	750	750	700	500	300
50	52	52	48	35	20
2½	750	750	700	500	300
65	52	52	48	35	20
3	750	750	700	500	300
80	52	52	48	35	20
4	750	750	700	400	250
100	52	52	48	28	17
5	750	750	600	300	NR
125	52	52	42	20	NR
6	700	700	500	300	NR
150	48	48	35	20	NR
8	600	600	400	150	NR
200	42	42	28	10	NR
10	500	500	300	100	NR
250	35	35	20	7	NR
12	400	400	250	100	NR
300	28	28	17	7	NR

LISTINGS/APPROVALS

The information provided below is based on the latest listing and approval data at the time of publication. Listings/Approvals are subject to change and/or additions by the approvals agencies. Contact **Shurjoint** for the performance on other pipes and the latest listings and approvals

Standard Pipe

Nom. Size	cULus	cULus/FM		VdS	LPCB
in mm	Sch. 5 PSI / Bar	Sch. 10 PSI / Bar	Sch. 40 PSI / Bar	Bar	PSI / Bar
1¼ 32	175 12	500 35	500 35	16	300 20
1½ 40	175 12	500 35	500 35	16	300 20
2 50	175 12	500 35	500 35	16	300 20
2½ 65	N/A	500 35	500 35	N/A	N/A
76.1mm	N/A	500 35	N/A	16	300 20
3 80	N/A	500 35	500 35	16	300 20
4 100	N/A	500 35	500 35	16	300 20
139.7mm	N/A	400 28	N/A	16	300 20
5 125	N/A	400 28	400 28	N/A	N/A
165.1mm	N/A	400 28	N/A	N/A	300 20
6 150	N/A	400 28	400 28	16	N/A
8 200	N/A	400 28	400 28	16	300 20
10 250	N/A	350 24	350 24	12.5	300 20
12 300	N/A	350 24	350 24	12.5	300 20

* Model Z07 incorporating Lube-E gasket is cULus listed and also suitable for use in dry pipe systems for temperatures to -40°F (-40°C).

General Notes:

- **Maximum Working Pressure (CWP)** listed is the maximum cold water pressure for general piping services tested to ASTM F1476 and or AWWA C606 methods. Figures listed are based on roll- or cut-grooved standard wall carbon steel pipe. For other pipe schedules or pipe materials, contact **Shurjoint** for additional information.
- **Max. End Load** is calculated based on the maximum working pressure (CWP).
- **Listed and or Approved Pressures** are pressure ratings for fire protection systems, tested and approved by various approval bodies. Please always refer to the latest approval data posted on the **Shurjoint** website.
- **Field Joint Test:** For one time only the system may be tested hydrostatically at 1½ times the maximum working pressure listed (AWWA C606 5.2.3).
- **Warning:** Piping systems must always be depressurized and drained before attempting disassembly and or removal of any components.
- **The 10 Year Limited Warranty** applies to manufacturing defects only and does not cover severe service/temperature applications or wear parts.
- **Shurjoint** reserves the right to change specifications, designs and or standard without notice and without incurring any obligations.