

# Technical Data Manual

Model Nos. and pricing : See Price List



## VITOCROSSAL 200

Gas-fired Condensing Boiler

399 to 2000 MBH (117 to 586 kW)



*Product may not be exactly as illustrated.*

### Vitocrossal 200

#### CI2 Series 399, 500, 750, 1000, 1500 and 2000

High efficiency, gas-fired condensing boiler with pre-mix modulating cylinder burners for natural gas (NG) or liquid propane gas (LPG), with Inox-Crossal heat exchanger made of high-grade SA240 stainless steel.

For operation without low limit on boiler return water temperature.

For closed loop hot water heating systems with maximum supply water temperatures of 210°F (99°C) for a maximum operating pressure of 80 psig.

Heating input: 399 to 2000 MBH  
(117 to 586 kW)



# Vitocrossal 200

**Benefits at a glance:**

- Low emissions and quiet operation from fully-modulating Viessmann pre-mix cylinder burners (up to 2 per boiler).
- Inox-Crossal heat exchanger surface made of high-grade SA240 stainless steel for high operational reliability and long service life.
  - Easy dispersal of condensate through vertical gas flues; therefore no concentration of condensate.
  - Increased self-cleaning effect through smooth stainless steel surfaces.
- Easy installation and elimination of wiring mistakes with Viessmann pre-wired plug-in system.
- Pre-mix cylinder burners for environmentally-friendly operation with a modulation range up to 30:1.
- Easy handling in boiler rooms through particularly compact size.
- Low NOx < 20 ppm (@3% O<sub>2</sub> with natural gas)
- Economical and safe heating system operation through digital control system with communication capability. Tailored to every need, covering all known control strategies and applications.
- Efficiency up to 98% through intensive condensation. The flue gas temperature is only approximately 9°F-27°F (5°C-15°C) above boiler return temperature.
- Clean combustion - through perfect match of burner and boiler, low combustion chamber loading and straight-through combustion chamber.
- Particularly quiet operation.
- High altitude operation up to 10,000 ft. (3000 m) with a simple electronic adjustment.
- Large water content extends burner run time and reduces cycling.

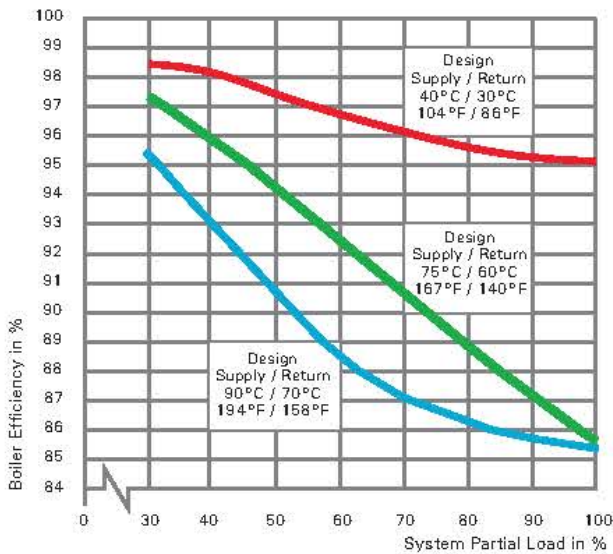

Vitocrossal 200 C12 boiler efficiency dependent on system heating water return temperatures and load conditions

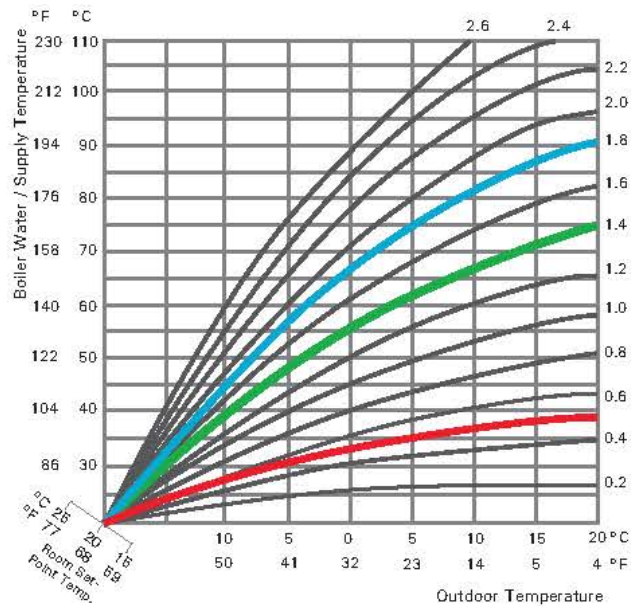

**Vitocrossal 200** (continued)

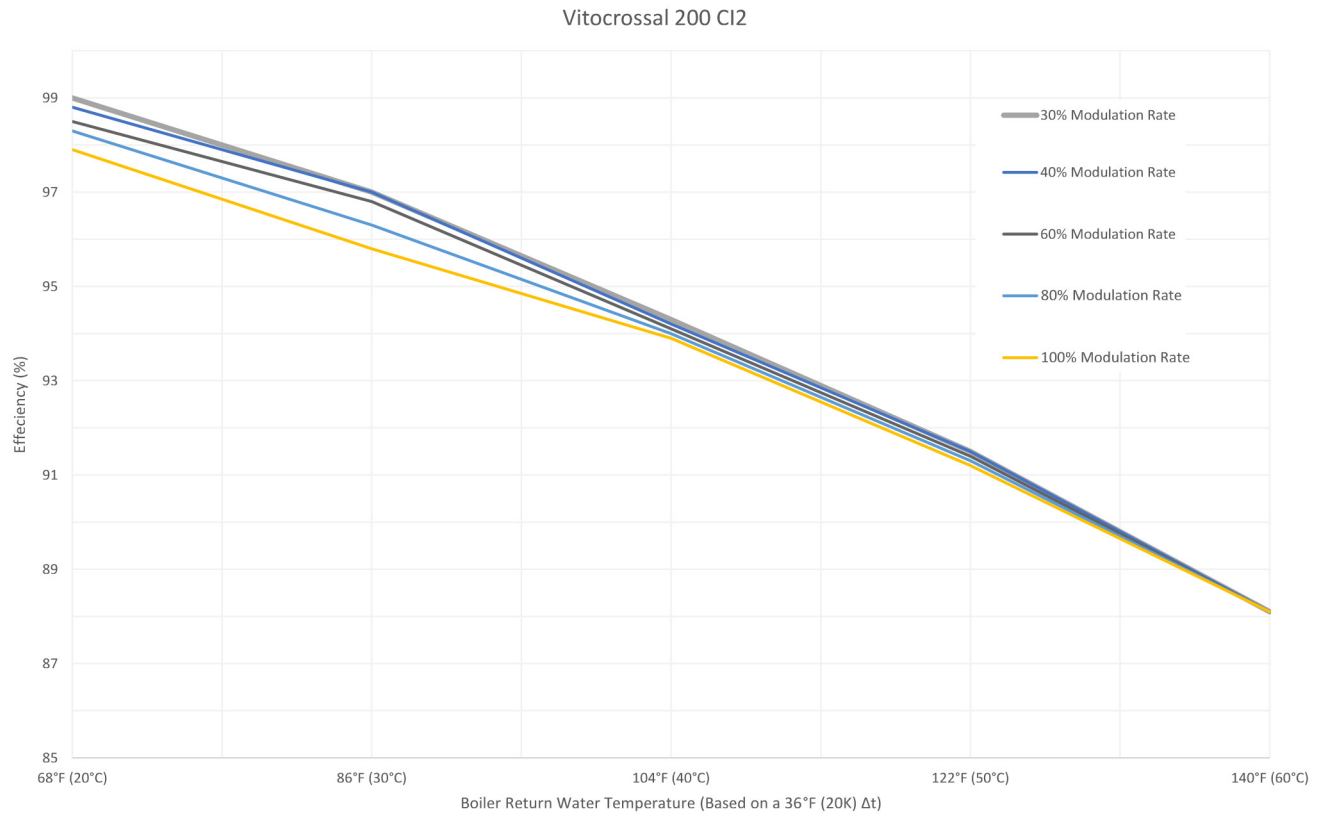

The Vitocrossal 200 CI2 has no minimum return water temperature limits.

**Cutaway Section**

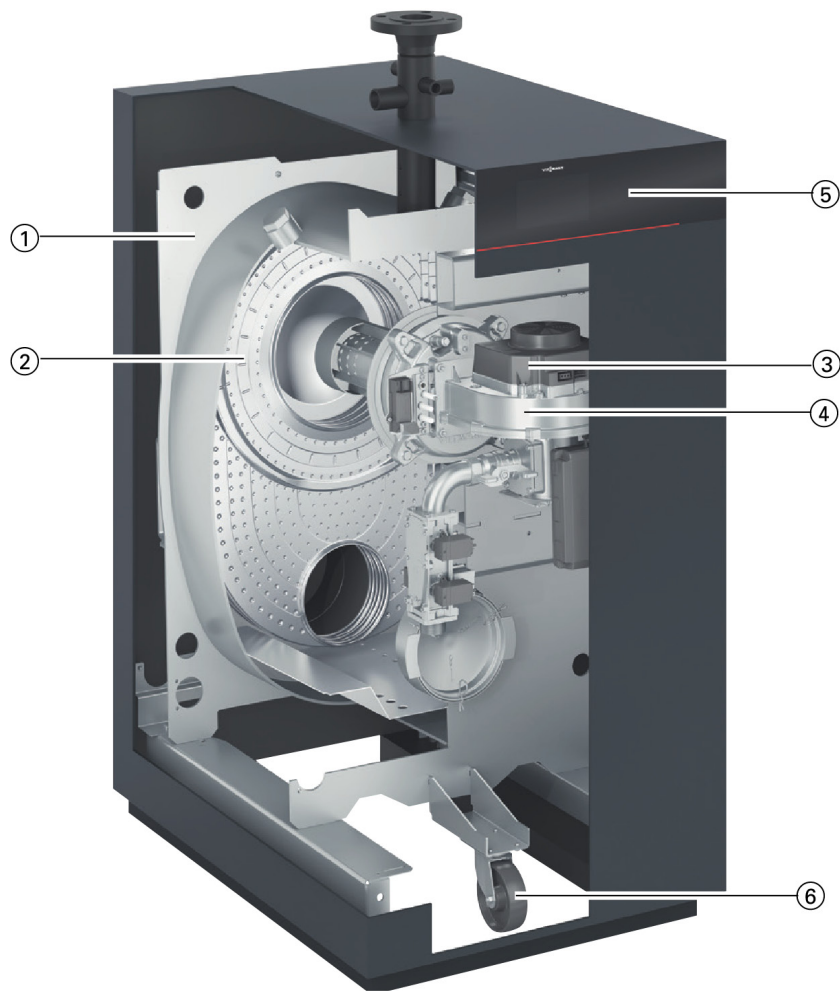

*Product may not be exactly as illustrated.*

**Legend**

- ① Pre-wired and pre-assembled
- ② High operational reliability and long service life through corrosion-resistant Inox-crossal heat exchanger surfaces made of high grade stainless steel
- ③ Fully modulating Matrix cylinder burner with a long service life
- ④ Constantly high efficiency with Lambda Pro Control combustion manager
- ⑤ Easy-to-use integrated control unit with 7 inch color touch screen and graphic display
- ⑥ Space-saving and compact, ideal for difficult handling conditions thanks to integrated casters

**Technical Data**

<b>Boiler Model</b>	<b>C12</b>	<b>399</b>	<b>500</b>	<b>750</b>	<b>1000</b>	<b>1500</b>	<b>2000</b>
<b>Input</b>	MBH	399	500	750	1000	1500	2000
	kW	117	147	220	293	440	586
<b>Minimum Input NG</b>	MBH	50	50	75	100	50	100
	kW	14.7	14.7	22.0	29.3	14.7	29.3
<b>Minimum Input LPG</b>	MBH	50	50	90	100	50	100
	kW	14.7	14.7	26.2	29.3	14.7	29.3
<b>Output (thermal efficiency)</b>	MBH	391	490	734	977	1460	1940
	kW	114	143	215	286	428	568
<b>Net AHRI Rating</b>	MBH	340	426	638	850	1270	1687
	kW	99	124	187	249	372	494
<b>Combustion Efficiency *1</b>	%	97	97	96.9	96.8	96.6	96.5
	<b>Thermal Efficiency *1</b>	%	98	97.9	97.8	97.7	97.3
<b>NG Supply Pressure</b>	"w.c. (min.)	4	4	4	4	4	4
	"w.c. (max.)	14	14	14	14	14	14
<b>LPG Supply Pressure</b>	"w.c. (min.)	10	10	10	10	10	10
	"w.c. (max.)	14	14	14	14	14	14
<b>Power Supply</b>	Voltage	120	120	120	120	120	120
	Phase	1	1	1	1	1	1
	Hz	60	60	60	60	60	60
	Amp.	20	20	20	20	20	20
<b>Overall Boiler Length</b> (including insulation and jacketing)	in.	39	39	47¼	47¼	56¼	56¼
	mm	992	992	1200	1200	1428	1428
<b>Overall Boiler Width</b> (including insulation and jacketing)	in.	29½	29½	29½	29½	29½	29½
	mm	750	750	750	750	750	750
<b>Overall Boiler Height</b> (including insulation and jacketing)	in.	64½	64½	64½	64½	78¾	78¾
	mm	1640	1640	1640	1640	1998	1998
<b>Concrete Boiler Base</b> Length	in.	32	32	41	41	47¼	47¼
	mm	812	812	1040	1040	1200	1200
Width	in.	29½	29½	29½	29½	29½	29½
	mm	750	750	750	750	750	750
Thickness	in.	0	0	0	0	0	0
	mm	0	0	0	0	0	0
<b>Weight</b> Complete with the burners, control, thermal insulation and jacketing	lb.	789	789	963	963	1812	1969
	Kg	358	358	437	437	822	893
<b>Boiler Water Content</b>	USG	29	29	50	50	113	99
	L	108	108	189	189	426	376
<b>Heat Exchanger Surface</b>	ft. <sup>2</sup>	65.2	65.2	129.4	129.4	196.2	258.8
	m <sup>2</sup>	6.1	6.1	12.0	12.0	18.2	24.0
<b>Fixed High Temperature Limit (Manual Reset)</b>	°F	210	210	210	210	210	210
	°C	99	99	99	99	99	99
<b>Maximum Adjustable Operating Temperature Limit (Auto Reset)</b>	°F	185	185	185	185	185	185
	°C	85	85	85	85	85	85
<b>Maximum Operating Pressure</b>	psig	80	80	80	80	80	80
	bar	5.5	5.5	5.5	5.5	5.5	5.5
<b>Minimum Pressure</b>	lb/hr	375	463	683	904	1345	1786
<b>Relief Valve Capacity</b>	Kg/hr	170	210	310	410	610	810

\*1 Tested to ANSI/AHRI standard 1500 Performance Rating of Commercial Space Heating Boilers / DOE Test Procedure 81 FR 89276 / U.S. Standards ANSI Z21.13/CSA 4.9.

The Vitocrossal 200 C12 series with Lambda Pro2 combustion technology regulates the oxygen level, automatically adjusting burner operation at the specific input rate. This combined with the electronic elevation setting in the boiler software allows the boiler to operate at altitudes of up to 10,000 ft. (3,000 m) without input derate.

**Technical Data** *(continued)*

Boiler Model	CI2	399	500	750	1000	1500	2000
<b>Boiler Electric Power Consumption without pumps or accessories (Watts)</b>							
Maximum Input		352	475	492	666	1064	1267
Minimum Input		54	54	74	79	103	134
Standby		17	17	20	20	70	70
<b>Boiler Connections</b>							
Boiler supply and return (BS), (BR) (NPT male thread)	in.	2	2				
	mm	50	50				
Boiler supply and return (BS), (BR) (ANSI flanges)	in.			2½	2½	4	4
	mm			65	65	100	100
Safety supply	in.	1¼	1¼	1¼	1¼	1¼	1¼
Boiler drain	in.	1½	1½	1½	1½	1½	1½
Condensate drain (barbed fitting)	in.	¾	¾	¾	¾	¾	¾
Gas connection	in.	1½	1½	1½	1½	2	2
<b>Boiler Flue Collar</b>							
Internal diameter	in.	4	4	6	6	6	8
	mm	104.2	104.2	155	155	155	205.2
Combustion Air Internal diameter (with combustion air intake kit)	in.	4	4	6	6	6	8
	mm	104.2	104.2	155	155	155	205.2
<b>Flue Gas Values</b>							
Temperature (at a return temperature of 86°F (30°C) at rated input)	°F	97	104	97	100	108	108
	°C	36	40	36	48	42	42
at partial load	°F	88	88	91	93	93	93
	°C	31	31	33	34	34	34
Temperature (at a return temperature of 140°F (60°C) at rated input)	°F	145	149	145	149	154	154
	°C	63	65	63	65	68	68
Mass flow rate (of flue gas) at rated input	lbs/h	359	452	675	899	1351	1799
	kg/h	163	205	306	408	613	816
at partial load	lbs/h	108	136	202	270	405	540
	kg/h	49	62	92	122	184	245
Max. Condensate Flow Rate for NG and LPG	USG/h	4	5	7	10	15	19
	L/h	14.6	18.4	27.5	36.6	55.0	73.3
Pressure at boiler flue outlet (at rated input)	pa	600	600	600	600	600	600
	(max.)						
	"w.c. (max.)	2.4	2.4	2.4	2.4	2.4	2.4
<b>Standby Loss</b>							
At boiler water temperature 122°F (50°C) [room temperature 68°F (20°C)]	BTU/h	2870	2870	2930	2930	4590	4590
	W	841	841	858	858	1345	1345
	%	0.8	0.7	0.4	0.3	0.3	0.3
NOx @3% O <sub>2</sub> (NG) *2		< 20 ppm					
<b>Communication Module (integral)</b>							
WiFi Frequency Band	MHz	2400 to 2483.5					
Maximum Transmission Power	dBm	15					
Lower Power Radio Frequency Band	MHz	2400 to 2483.5					
Maximum Transmission Power	dBm	6					

\*2 The Vitocrossal 200 CI2 boilers are certified to the requirements of South Coast Air Quality Management District (SCAQMD) Rule 1146.2, Bay Area Air Quality Management District (BAAQMD) Regulation 9 Rule 6.

## Boiler Dimensions

### CI2 399, 500, 750 and 1000

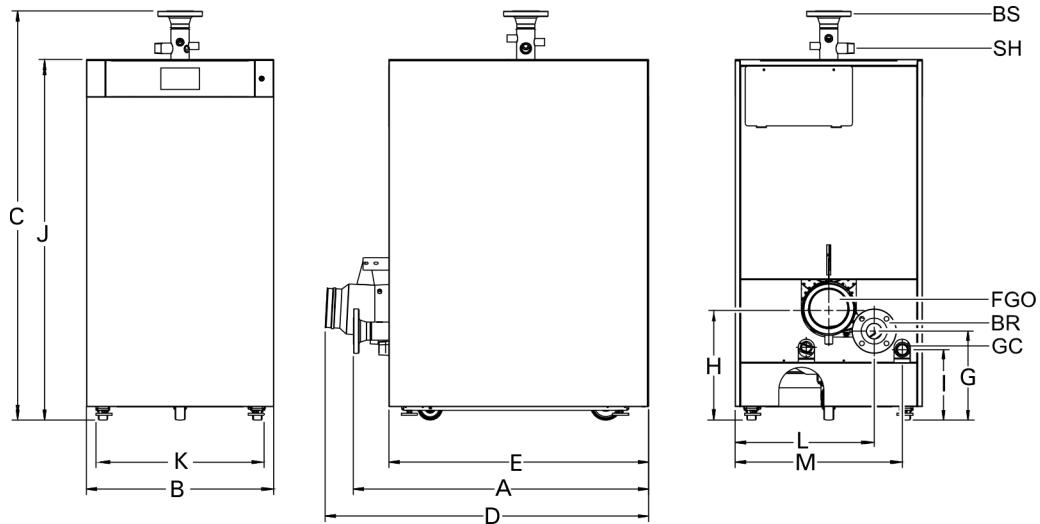

### CI2 1500 and 2000

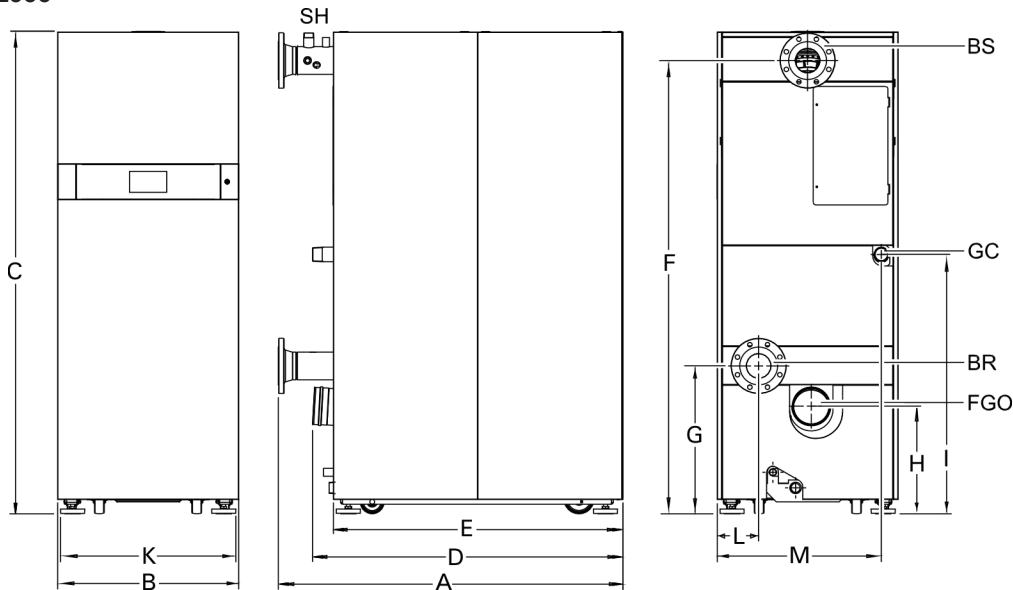

#### Dimensions

Boiler Model	399/500	750/1000	1500/2000
A	in. (mm) 35¾ (909)	46½ (1183)	56¼ (1428)
B	in. (mm) 29½ (750)	29½ (750)	29½ (750)
C*	in. (mm) 64½ (1640)	64½ (1640)	78¾ (1998)
D	in. (mm) 39 (992)	47¼ (1200)	51 (1297) <b>1500</b> 51 (1295) <b>2000</b>
E	in. (mm) 32 (812)	41 (1040)	47¼ (1200)
F	in. (mm) --	--	74 (1875)
G	in. (mm) 14½ (366)	14 (358)	24 (612)
H	in. (mm) 18 (457)	17¼ (444)	15¾ (398) <b>1500</b> 15 (383) <b>2000</b>
I	in. (mm) 11 (283)	11 (283)	42¼ (1073)
J	in. (mm) 57 (1452)	57 (1452)	--
K	in. (mm) 26½ (674)	26½ (674)	28½ (726)
L	in. (mm) 22 (557)	22 (557)	6¾ (172)
M	n. (mm) 26½ (670)	26½ (670)	26¾ (680)

**Note:** dimensional tolerance of ± ¼ in. (± 5 mm)

#### Legend

- SH Safety Header
- BS Boiler Supply
- GC Gas Connection
- BR Boiler Return
- FGO Flue Gas Outlet (vent pipe connection)

\* Height to the bottom of the casters.

## Recommended Minimum Service Clearances

CI2 399, 500, 750 and 1000

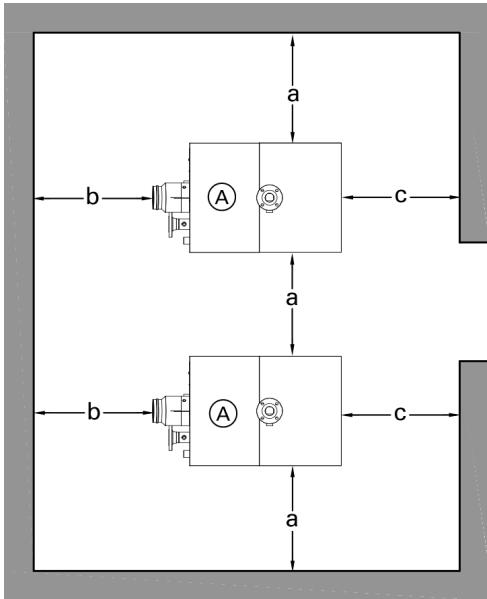

CI2 1500 and 2000

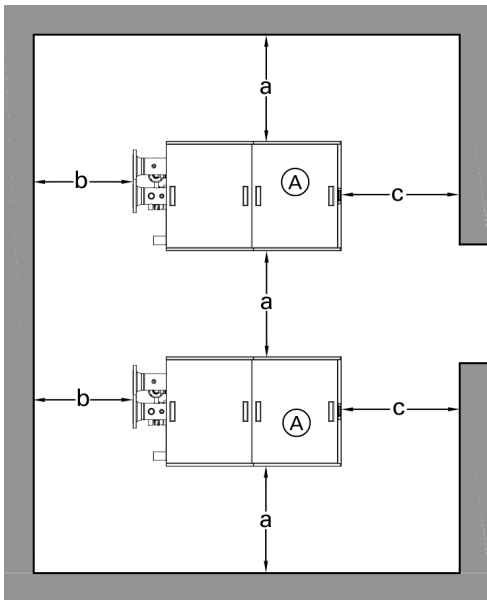

**Legend**

(A) Boiler

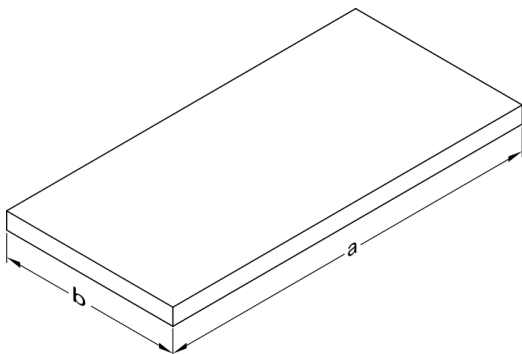

To enable convenient installation and maintenance, observe the stated clearance dimensions. Maintain the minimum clearances where space is tight.

CI2 Model	399	500	750	1000	1500	2000
a*2 in. mm	27½ 700	27½ 700	27½ 700	27½ 700	27½ 700	27½ 700
b*1 in. mm	31½ 800	31½ 800	31½ 800	31½ 800	31½ 800	31½ 800
c in. mm	39½ 1000	39½ 1000	39½ 1000	39½ 1000	39½ 1000	39½ 1000
Top clearance in. mm	20 510	20 510	20 510	20 510	20 510	20 510

\*1 Clearance for vent pipe installation.

\*2 Clearance between boilers can be reduced to 0 in. (0 mm) in multi-boiler installation.

**Mechanical room**

- Avoid air contamination by halogenated hydrocarbons (e.g. as in sprays, paints, solvents and cleaning agents)
- Avoid very dusty conditions
- Avoid high levels of humidity
- Protect against frost and ensure good ventilation, otherwise the system may suffer faults and damage. In rooms where air contamination from halogenated hydrocarbons is to be expected, operate the boiler using only direct vent (sealed combustion) operation only.

**Minimum clearances to combustibles**

CI2 Model	399	500	750	1000	1500	2000
Top	0					
Sides	0					
Flue	per vent manufacturer's specifications					
Front	0					
Floor	combustible					

**Concrete pad (if required)**

**Without seismic feet**

CI2 Model	399	500	750	1000	1500	2000
a in. mm	32 812	32 812	41 1040	41 1040	47¼ 1200	47¼ 1200
b in. mm	29½ 750	29½ 750	29½ 750	29½ 750	29½ 750	29½ 750

**With seismic feet**

CI2 Model	399	500	750	1000	1500	2000
a in. mm	46 1170	46 1170	54 1370	54 1370	63 1600	63 1600
b in. mm	46 1170	46 1170	46 1170	46 1170	46 1170	46 1170

# Flow Rate

## Pressure drop (primary circuit)

The Vitocrossal 200, CI2 is only suitable for fully pumped hot water heating systems.

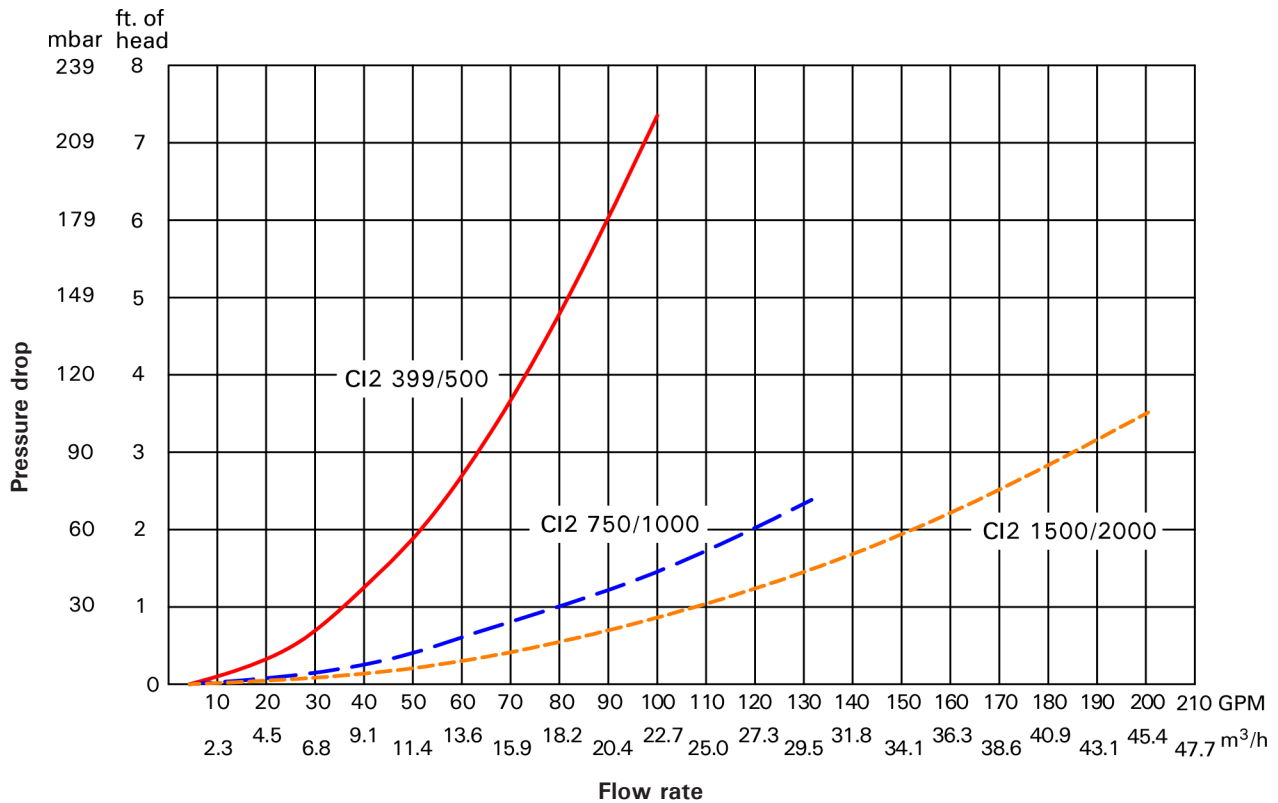

### Recommended Flow Rates CI2

CI2 model		399	500	750	1000	1500	2000
20°F Δt	GPM	39	48	73	97	146	194
40°F Δt	GPM	19	24	36	49	73	97
100°F Δt	GPM	8	10	15	19.5	29	39
11°C Δt	m³/h	8.9	10.9	16.6	22.0	33.2	44.1
22°C Δt	m³/h	4.3	5.5	8.2	11.1	16.6	22.0
56°C Δt	m³/h	1.8	2.3	3.4	4.4	6.6	8.9

Δt = temperature difference

This boiler does not require a flow switch.

Minimum flow rate based on: 100°F Δt (56°C Δt)

Maximum flow rate based on: 20°F Δt (11°C Δt)

# Cylinder Burner

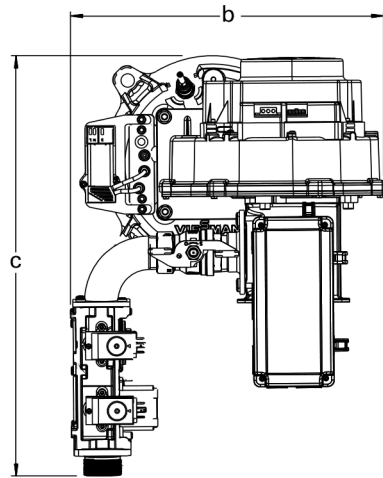

### Dimensions

CI2 Burner model		399 / 500	750 / 1000
a	in. (mm)	19 (481)	28¾ (731)
b	in. (mm)	17¼ (437)	15½ (395)
c	in. (mm)	20¼ (516)	21 (530)
d	in. (mm)	11 (280)	14¼ (363)

### Burner Combinations

CI2 model	Burner Input MBH	
	Upper	Lower
1500	500	1000
2000	1000	1000

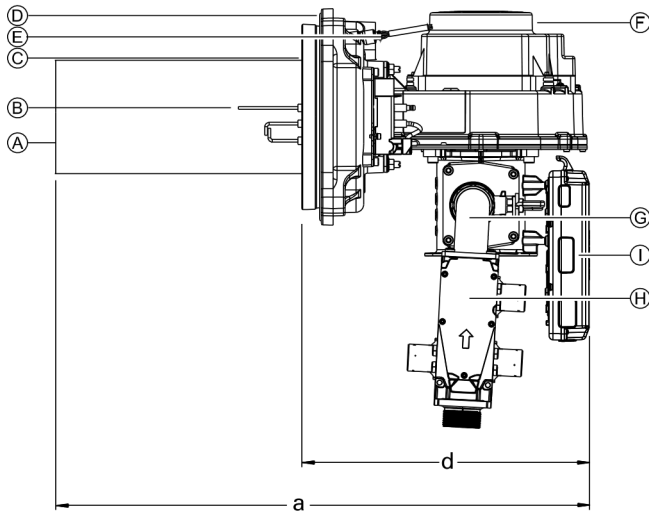

### Legend

- (A) Burner tube
- (B) Ignition electrodes
- (C) Insulation Block
- (D) Burner door
- (E) Lambda probe (O<sub>2</sub> sensor)
- (F) Burner fan
- (G) Gas train
- (H) Gas valve
- (I) E box (750 and 1000 MBH burner only)

## Standard Equipment

Boiler body is fitted with protective caps on all connectors and fitted protective crate.

C12 Boiler model	399	500	750	1000	1500	2000
Thermal insulation	1	1	1	1	1	1
Cylinder burners	1	1	1	1	2	2
Integrated boiler control unit with 7 in. touchscreen display	1	1	1	1	1	1
Technical documentation	1	1	1	1	1	1
NG to LPG labelling kits	1	1	1	1	1	1

Installation fittings for standard equipment includes:

- low water cut-off
- gas shut off valve
- safety header (c/w 80 psig pressure relief valve, air vent and temperature/pressure gauge)
- drain valve
- product documentation

Alternate pressure relief valves are available, please contact your Viessmann sales representative.

### Permissible Ambient Conditions

#### During Operation:

For installation in living spaces or boiler rooms (standard ambient conditions)

Temperature Range 32 to 104°F (0 to 40°C)

Relative humidity of less than 95%, non condensing

#### During Storage:

Stored indoors (no exposure to outside elements)

Temperature range of -13 to 113°F (-25 to 45°C)

Relative humidity of less than 95%, non condensing

#### Combustion Air:

Allowable combustion air temperature range for boilers using direct vent system -31 to 108°F (-35 to 42°C).

## Boiler Control Alternatives

### For single boiler systems

Single boiler operating with outdoor reset and modulating water temperature. Mixing valve control for a maximum of 3 heating circuits with mixing valve and 4 zone circuits.

### For multiple boiler installations

The integrated 7 in. touchscreen boiler control can be cascaded up to 16 boilers (1 lead and 15 lag boilers).

Outdoor reset control for cascade operation with zone circuit control for up to 4 zone circuits and 3 mixing valve circuits with accessory mixing valve extension modules.

### For single boiler or multiple boiler installations

Custom control panels for residential or commercial applications are designed and manufactured by Viessmann to suit any customer's specific requirements. Custom control panels can integrate features such as pool heating, hot tub heating, snow melting, internet tie-in, integration with Building Management Systems, as well as other functions. Please inquire.

## General

The schematics on the following pages are to be seen as guidelines only. They further do not display all system varieties, safety devices, or concepts possible. Specific system layouts may be further discussed with the local Viessmann sales representative office.



### CAUTION

For underfloor heating applications, an additional immersion or strap-on aquastat must be installed in the low temperature underfloor loop (downstream of the mixing valve) to de-energize the pump and/or boiler to prevent overheating. High water temperatures can damage concrete slabs.

### IMPORTANT

The examples on the following pages depict possible piping layouts of the Vitocrossal 200, CI2 boiler equipped with Viessmann System Technology.

For boiler and tank combinations, please install only feasible combinations listed in the Viessmann Price List.

Please note that the following examples are simplified conceptual drawings only!

Piping and necessary componentry must be field verified.

A low water cut-off (LWCO) must be installed where required by local codes.

Proper installation and functionality in the field is the responsibility of the heating contractor.



### WARNING

If a DHW storage tank other than a Viessmann Vitocell 300 tank is used, the installer must verify proper operation of the Viessmann DHW tank temperature sensor with the original manufacturer of the tank. Viessmann strongly recommends the installation of a temperature tempering valve in the DHW supply line.

### IMPORTANT

For DHW tank applications, perform, accurate calculations for DHW tank coil pressure drop DHW boiler pump (field supplied) residual head to ensure sufficient water flow to the boiler heat exchanger. Failure to heed the above instructions may cause boiler short-cycling and inadequate DHW supply.

**Note:** In the following piping layout examples all pumps are field supplied.

# System Layout 1

Vitocrossal 200, CI2 with...

- DHW storage tank
- 3 zone circuits
- 3 heating circuits with a mixing valve

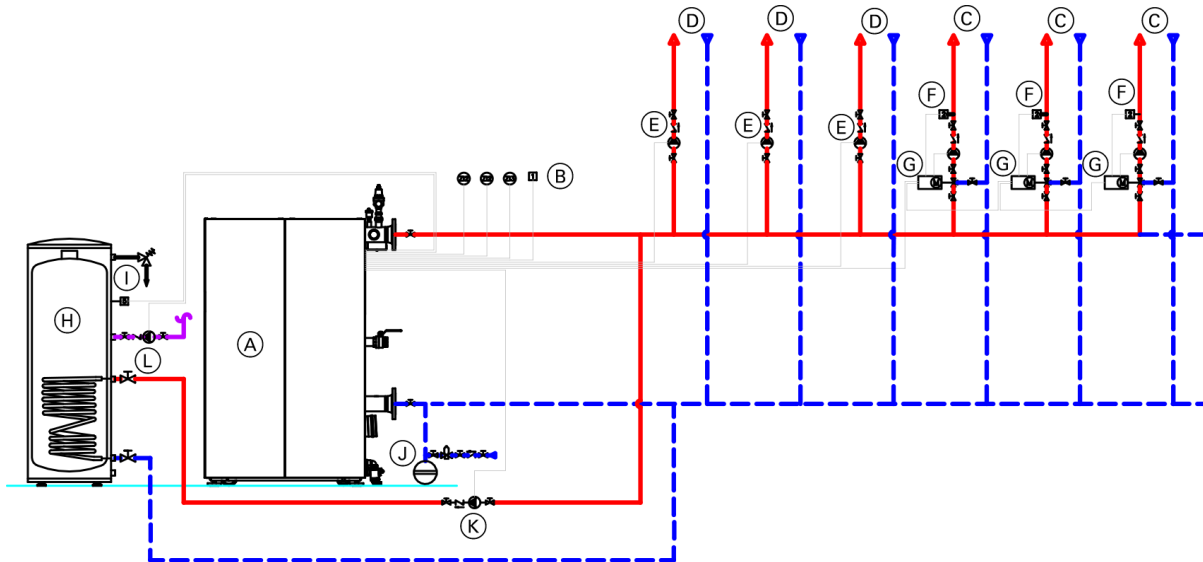

**Legend**

- (A) Vitocrossal 200, CI2 boiler
- (B) Outdoor temperature sensor [1]
- (C) Low temperature heating circuit
- (D) Zone circuit
- (E) Zone pump
- (F) Mixing valve temperature sensor [2]
- (G) Mixing valve with actuator
- (H) Domestic hot water storage tank
- (I) DHW tank temperature sensor [5]
- (J) Expansion tank
- (K) DHW pump [PI]
- (L) DHW recirculation pump

Installation of different heating circuits...

- 3 zone circuits (radiator heating circuit)
- 3 low-temp. circuits (under floor heating circuit with 3-way mixing valve)
- DHW production with DHW recirculation

The 3-way mixing valve control, to achieve the low-temperature level of the under floor heating circuit, an accessory kit for a heating circuit with mixing valve is required.

**IMPORTANT**

System separation is required of underfloor heating systems employing non-oxygen diffusion barrier tubing. All components on the secondary side of the heat exchanger must be made of corrosion-resistant materials.

## System Layout 2

Vitocrossal 200, C12 with...

- DHW storage tank
- 3 zone circuits
- 3 heating circuits with a mixing valve

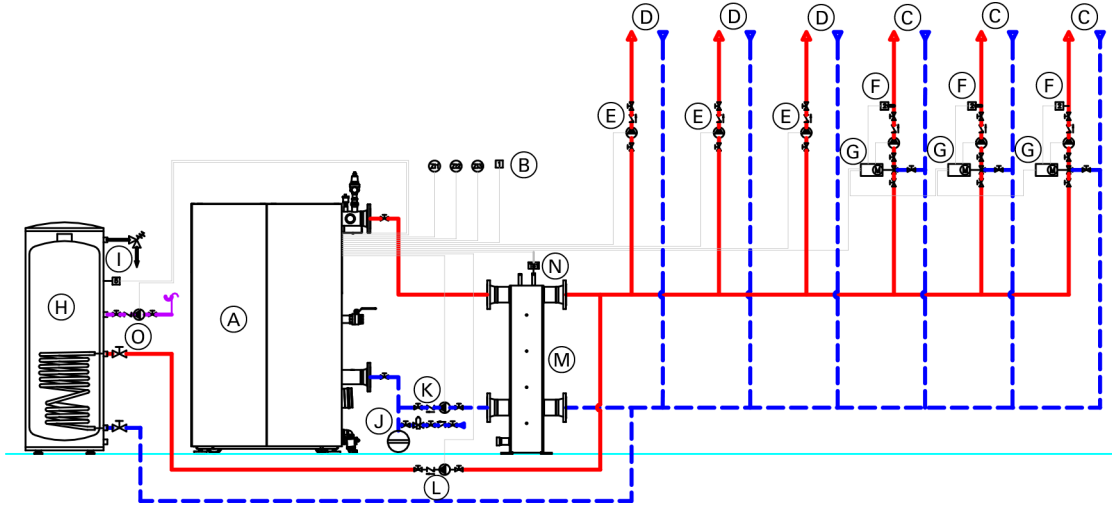

### Legend

- (A) Vitocrossal 200, C12 boiler
- (B) Outdoor temperature sensor 1
- (C) Low temperature heating circuit
- (D) Zone circuit
- (E) Zone pump
- (F) Mixing valve temperature sensor 2
- (G) Mixing valve with actuator
- (H) Domestic hot water storage tank
- (I) DHW tank temperature sensor 5
- (J) Expansion tank
- (K) Boiler pump/system pump
- (L) DHW pump P1
- (M) Low loss header
- (N) System supply temperature sensor TSI
- (O) DHW recirculation pump

Installation of different heating circuits...

- 3 zone circuits (radiator heating circuit)
- 3 low-temp. circuits (under floor heating circuit with 3-way mixing valve)
- DHW production with DHW recirculation

The 3-way mixing valve control, to achieve the low-temperature level of the under floor heating circuit, an accessory kit for a heating circuit with mixing valve is required.

### IMPORTANT

**System separation is required of underfloor heating systems employing non-oxygen diffusion barrier tubing. All components on the secondary side of the heat exchanger must be made of corrosion-resistant materials.**

# System Layout 3

Multiple (up to 16 boilers) Vitocrossal 200, C12 with...

- 3 heating circuits with mixing valves
- low-loss header
- 3 zone circuits
- DHW

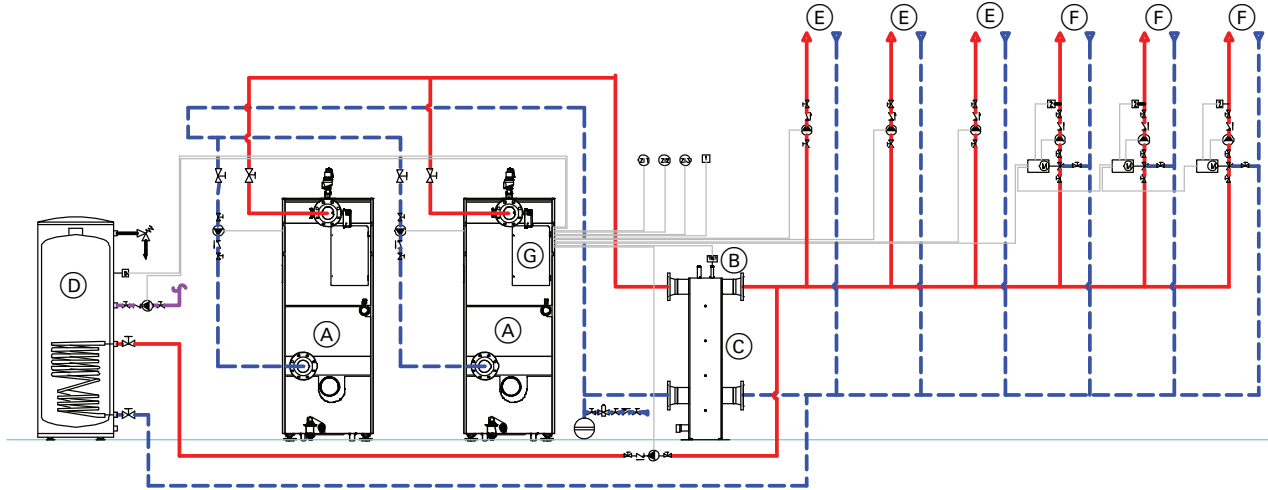

### Legend

- (A) Vitocrossal 200, C12 boiler
- (B) Low-loss header/common supply temperature sensor TSI on lead boiler
- (C) Low-loss header
- (D) DHW storage tank
- (E) Zone circuit
- (F) Low temperature heating circuit
- (G) Connection to BMS (BACnet/MODbus)

Each boiler in a cascade system must be able to be individually isolated from the heating system through the use of boiler isolation valves.

When designing a multiple Vitocrossal 200, C12 system as shown above, please reference applicable multiple Vitocrossal 200, C12 technical documentation, and contact your local Viessmann Sales Representative for further assistance.

This installation example depicts a possible piping layout for multiple Vitocrossal 200, C12 boilers equipped with Viessmann System Technology. Please note that this example is based on a simplified conceptual drawing only! Piping and necessary componentry must be field verified. A low water cut-off (LWCO) must be installed where required by local codes.

Proper installation and functionality in the field is the responsibility of the heating contractor.

### **!** WARNING

If a DHW storage tank other than a Viessmann Vitocell 300 tank is used, the installer must verify proper operation of the Viessmann DHW tank temperature sensor with the original manufacturer of the tank. Viessmann strongly recommends the installation of a temperature tempering valve in the DHW supply line.

## System Layout 4

Multiple (up to 16 boilers) Vitocrossal 200, C12 with...  
 - system pump  
 - DHW

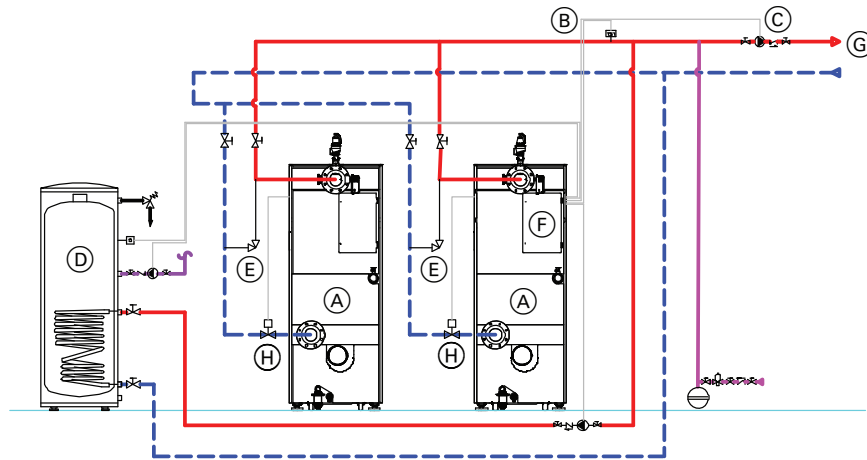

### Legend

- (A) Vitocrossal 200, C12 boiler
- (B) Common supply temperature sensor TSI on lead boiler
- (C) Common boiler pump
- (D) DHW storage tank
- (E) Hydronic pressure bypass (if required)
- (F) Connection to BMS (BACnet/MODbus)
- (G) Heating system
- (H) Boiler isolation valve (power open/spring return)
- \* Optional accessory (depending on system layout and configuration)

**Note:** When using constant boiler/system pumps, a hydronic pressure bypass may be required.

Each boiler in a cascade system must be able to be individually isolated from the heating system through the use of boiler isolation valves.

When designing a multiple Vitocrossal 200, C12 system as shown above, please reference applicable multiple Vitocrossal 200, C12 technical documentation, and contact your local Viessmann Sales Representative for further assistance.

This installation example depicts a possible piping layout for multiple Vitocrossal 200, C12 boilers equipped with Viessmann System Technology. Please note that this example is based on a simplified conceptual drawing only! Piping and necessary componentry must be field verified. A low water cut-off (LWCO) must be installed where required by local codes.

Proper installation and functionality in the field is the responsibility of the heating contractor.

### WARNING

If a DHW storage tank other than a Viessmann Vitocell 300 tank is used, the installer must verify proper operation of the Viessmann DHW tank temperature sensor with the original manufacturer of the tank. Viessmann strongly recommends the installation of a temperature tempering valve in the DHW supply line.

## Boiler Piping in Heating/Cooling Application

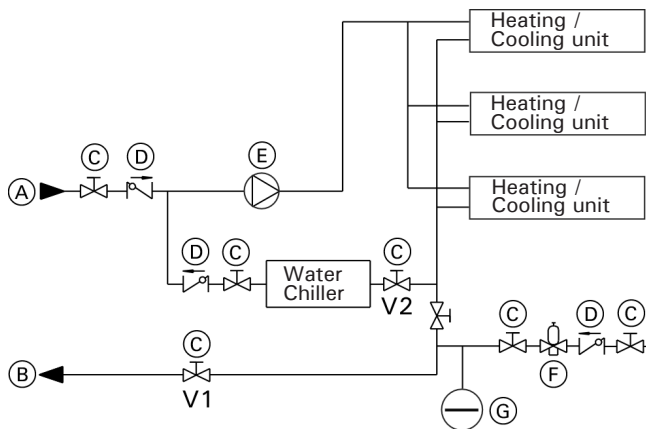

**Legend**

- (A) System supply
- (B) System return
- (C) Valve
- (D) Supply check valve
- (E) Circulation pump
- (F) Automatic feed valve
- (G) Pre-charged expansion tank

The Vitocrossal 200, CI2 boiler, when used in connection with a refrigeration system, must be installed so that the chilled medium is piped in parallel to the boiler and with appropriate valves to prevent the chilled medium from entering the boiler.

The boiler piping system of a hot water heating boiler is connected to the heating coils located in the air handling units. The boiler piping system may be exposed to chilled water and must be equipped with flow control valves or other automatic means to prevent gravity circulation of the boiler water during the cooling cycle.

Check the installation instructions of the chiller manufacturer carefully for additional requirements.

Cooling season starts: Close valve V1 and open valve V2.

Heating season starts: Close valve V2 and open valve V1.

Metal tags labelling these valves should be attached.

### IMPORTANT

**In the above system, the circulating pump must be operated from a separate on/off switch - not from the boiler control.**

## System Design Considerations

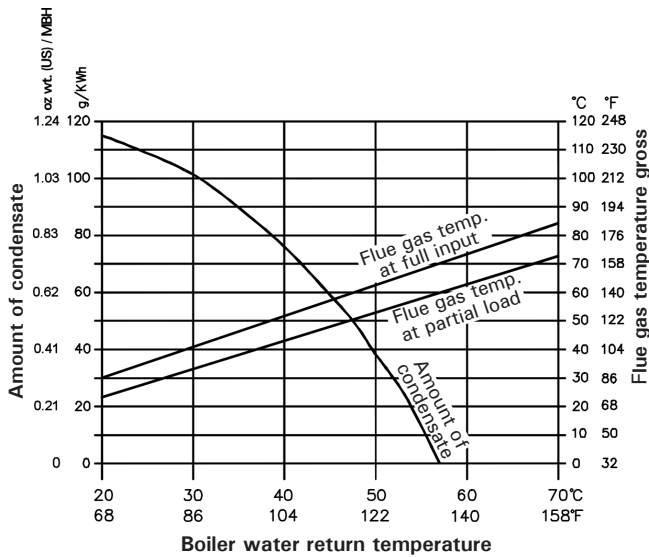

**Note:** The 'amount of condensate' and the 'flue gas temperature gross' graphs are independent of each other.

### Condensate and its disposal

During the operation of the boiler, the amount of condensate to be expected can be read from the above diagram.

The values given are approximate amounts occurring under practical conditions. Not included in the diagram is the amount of condensate occurring in the vent pipe and chimney system. The condensate from the chimney system can be collected together with the condensate from the heating boiler and be disposed of into a floor drain. The condensate will be between 3 and 4 on the pH scale. If local building requirements demand neutralizing the condensate before disposal, contact Viessmann Manufacturing Company Inc. for a correctly sized neutralization tank. The treated condensate will show pH values of between 6.5 and 9 and can then be disposed of into the waste water system.

### Design notes regarding draining condensate

The condensate drain to the sewer connection must be able to be inspected. Route it with a gradient and equip the pipe with a P-trap; also provide suitable facilities for taking samples. The condensate drain must slope downward away from the boiler to a level below the condensate trap.

Condensate drains must only be made from corrosion resistant materials (e.g. fibre reinforced hoses). Never use any galvanized materials or those containing copper or black iron for pipes, connectors, etc. Install a P-trap in the condensate drain to prevent flue gases from escaping.

Ensure that the domestic drainage systems are made from materials which are resistant to acidic condensate such as:

- Stoneware pipes
- Hard PVC pipes
- PVC pipes
- PE-HD pipes
- PP(s) pipes
- ABS/ASA pipes
- Stainless steel pipes
- Borosilicate pipes

### Burner adjustment

Matrix cylinder burners are tested at operating temperature and adjusted at the factory.

**System Design Considerations** *(continued)*

**Venting options**

PP(s) (Polypropylene) flue gas/fresh air system for room air independent operation (sealed combustion), and PP(s) flue gas for room air dependent operation are tested to ANSI Z21.13 - CSA 4.9 (most recent edition) standards and are certified together with the Vitocrossal 200 C12 boiler as a constructional unit.

The boiler may be vented horizontally through the side wall or vertically through the roof.

For a more detailed description of the direct vent and single-wall vent system, please refer to the Vitocrossal 200 C12 Installation Instructions venting section.

Use ULC S-636 / UL 1738 certified venting systems for category IV boilers. The following vent system suppliers may be contacted for assistance in designing the appropriate stainless steel venting system for Vitocrossal 200 C12 boilers.

<b>Duravent</b> www.duravent.com	<b>ICC - Industrial Chimney Co.</b> www.icc-rsf.com
<b>Selkirk Canada Corporation</b> www.selkirkchimney.com	<b>Z-Flex US Inc. (flexmaster Canada)</b> www.Z-flex.com
<b>Security Chimneys International Ltd.</b> www.securitychimneys.com	<b>Energex Inc. (formerly Exhausto)</b> www.energex.com
<b>Jeremias Inc.</b> www.jeremiasinc.com	<b>Van-Packer Co. Inc.</b> www.vpstack.com
<b>METAL-FAB, INC.</b> www.mtlfab.com	

**Vent System Suppliers**

Use special venting system (UL/ULC listed for Category IV) for exhaust vent material of the Vitocrossal boilers. Contact one of the following suppliers to order parts.

These suppliers deliver PP(s) rigid and flexible vents in a variety of sizes.

<b>Duravent</b> www.duravent.com	<b>Centrotherm InnoFlue</b> www.centrotherm.us.com
<b>ECCO Manufacturing</b> www.eccomfg.com	<b>Z-Flex US Inc. (flexmaster Canada)</b> www.Z-flex.com

**System layout**

The boiler max. water temperature limit is factory set to 185°F (85°C).

To minimize piping losses of the system, however, Viessmann recommends that the radiation and domestic hot water production in the system be designed for a 158°F (70°C) boiler supply water temperature.

**Oxygen diffusion barrier under floor tubing**

The boiler warranty does not cover pressure vessel failure resulting from corrosion caused by the use of underfloor plastic tubing without an oxygen diffusion barrier. Such systems without oxygen diffusion barrier must have the tubing separated from the boiler with a heat exchanger. Viessmann always recommends the use of underfloor plastic tubing with an oxygen diffusion barrier.

**Boiler/burner start-up**

Vitocrossal 200 C12 boilers with Viessmann cylinder burners does not require start-up by Viessmann.

**Combustion air supply**

The boiler must not be located in areas or rooms where chemicals containing chlorine, bromine, fluorine, or other corrosive chemicals are stored. Examples include bleach, refrigerants, paint, paint thinner, hair spray, cleaning solvents, water softener salt, etc. The combustion air must not be contaminated with any amount of the above mentioned chemicals.

Boiler should never be installed in areas where excessive dust, high humidity, or risk of frost exist. Ensure adequate ventilation and supply of fresh combustion air.

**System Design Considerations** *(continued)*

**Boiler operation in marine environments (damp, salty coastal areas):**

The service life of the boiler’s exposed metallic surfaces, such as the casing and fan housing, is directly influenced by proximity to damp and salty marine environments. In such areas, higher concentration levels of chlorides from sea spray, coupled with relative humidity, can lead to degradation of the exposed metallic surfaces mentioned above. Therefore, it is imperative that boilers installed in such environments not be installed using direct vent systems which draw outdoor air for combustion. Such boilers must be installed using room air dependent vent systems; i.e. using room air for combustion. The indoor air will have a much lower relative humidity and, hence, the corrosion will be minimized.

Consult your local Viessmann sales representative with uncertainties in regard to a suitable boiler installation location.

This boiler/burner unit needs clean fresh air for safe operation. Provisions for combustion and ventilation air must be made at time of installation. For gas or propane installations, use the “Natural Gas Installation Code CAN/CSA-B149.1 or B149.2” (Canada), or “National Fuel Gas Code ANSI Z223.1” (USA), and/or provisions of local codes.

The sizing methods outlined in the aforementioned codes should be used when installing a round duct to supply combustion air from the outside.

**Warranty**

Our warranty does not cover damages resulting from the following:

- Operation with contaminated fill and supplementary feed water
- Operation with contaminated combustion air
- Exposing the boiler to pressures and temperatures higher than its certified rating

See warranty sheet for details.

**Water quality**

Treatment for boiler feed water should be considered in areas with known problems, such as where a high mineral content and hardness exist. In areas where freezing might occur, it recommended that an antifreeze be added to the system water for protection against freezing. Please adhere to the specifications given by the antifreeze manufacturer. Do not use automotive silicate-based antifreeze. Please observe that an antifreeze/water mixture may require a back flow preventer within the automatic water feed and influence components such as diaphragm expansion tanks, radiation, etc. A 40% antifreeze content will provide freeze-up protection to -10°F (-23°C). Do not exceed 50% antifreeze mix ratio and do not use antifreeze other than specifically made for hot water heating systems.

Total output (MBH)	Total Hardness (ppm of CaCO <sub>3</sub> )
≤170	300
> 170 to ≤680	200
> 680 to ≤2000	150
> 2000	2

The pH value of the heating water should be between 8.2 and 9.5

The standard values assume the following:

- The total volume of fill and top-up water during its service life will not exceed three times the water content of the heating system.

Soften the fill and top-up water in heating systems operating under the following conditions:

- The total of alkaline earths in the fill and top-up water exceeds the standard value.
- Higher fill and top-up water volumes are expected.

Only fill the boiler with water that conforms with water quality guidelines of IAPMO/ANSI H1001.1.

## System Design Considerations *(continued)*

### Sound attenuation

Please consult a professional engineer who is specialized in noise attenuation for advice.

The burner/boiler systems, circulation pumps and other auxiliary equipment used in heating systems generate noise.

This noise is transferred from the boiler room via floorboards, ceiling and walls to neighboring rooms and via the flue gas system as well as the ventilation air and exhaust air apertures into other rooms and into the open, where they may cause a nuisance.

To avoid this from happening, additional protective measures may be required which should be considered at the design stage.

Subsequent measures to reduce noise nuisance frequently require extensive effort and expenditure.

### Airborne noise attenuation

Frequently, modern boilers are equipped with silencer hoods or sound insulated ventilation air inlet housings.

For larger systems, it may be necessary to route the ventilation air through a sound-insulated channel, in order to avoid a noise nuisance outside the building.

Flue gas silencers are generally only required where higher noise protection measures are called for. Whether or not a flue gas silencer is required can be predicted only with some difficulties, because of the complexity of the creation and propagation of flame noise, the interaction between the burners, boilers and the flue gas system as well as the operating mode (flue gas system operating with positive or negative pressure).

It is advisable, therefore, to assess the noise emission into the neighborhood and to consider the sound pressure level measured at the flue gas system outlet. It should be considered at the planning stage whether silencers might become necessary later.

In planning for its possible use, it is important that sufficient space for the flue gas silencer is available behind the boiler. Good engineering practice mandates that the exhaust pressure drop of the silencer be included in the vent size calculation.

### Anti-vibration measures

Anti-vibration supports can be field supplied as an economical and effective solution to combat noise generated.

When sizing such supports, take the entire operating weight of the boiler system and, when using longitudinal anti-vibration brackets, the condition of the supporting surface into consideration.

Effective anti-vibration measures are particularly important when installing boilers into an attic. Flexible couplings may be used to physically separate the combustion equipment from the building.

These should be installed into the boiler flow, return and safety pipe and as near as possible to the boiler. Also insulate any braces or hanging arrangements, if installed, against sound/vibration transmission to the building.

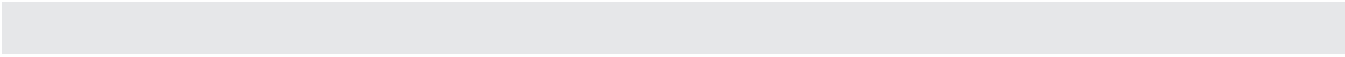

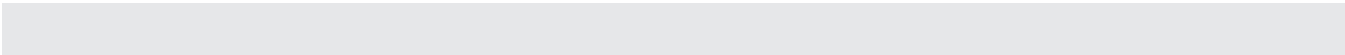

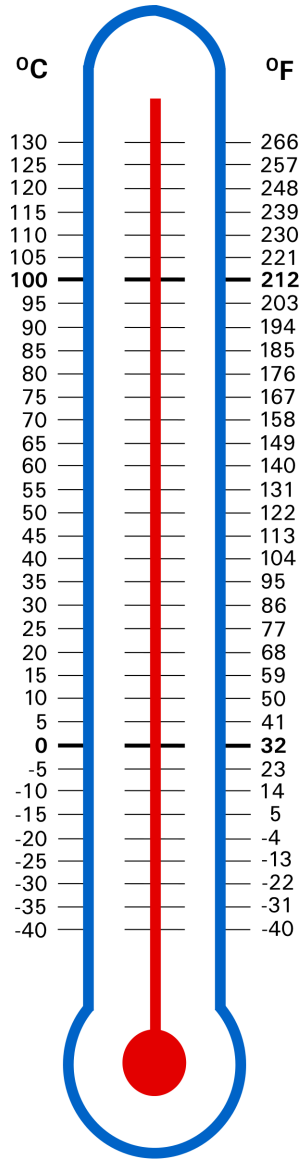

Printed on environmentally friendly  
(recycled and recyclable) paper.



Technical information subject to change without notice.

Scan for a digital copy of this document



Viessmann Manufacturing Company Inc.  
750 McMurray Road  
Waterloo, Ontario • N2V 2G5 • Canada  
**TechInfo Line 1-888-484-8643**  
1-800-387-7373 • Fax (519) 885-0887  
[www.viessmann.ca](http://www.viessmann.ca) • [info@viessmann.ca](mailto:info@viessmann.ca)

Viessmann Manufacturing Company (U.S.) Inc.  
45 Access Road  
Warwick, Rhode Island • 02886 • USA  
**TechInfo Line 1-844-649-5886**  
1-800-288-0667 • Fax (401) 732-0590  
[www.viessmann-us.com](http://www.viessmann-us.com) • [info@viessmann-us.com](mailto:info@viessmann-us.com)